

Top-Level Diagram

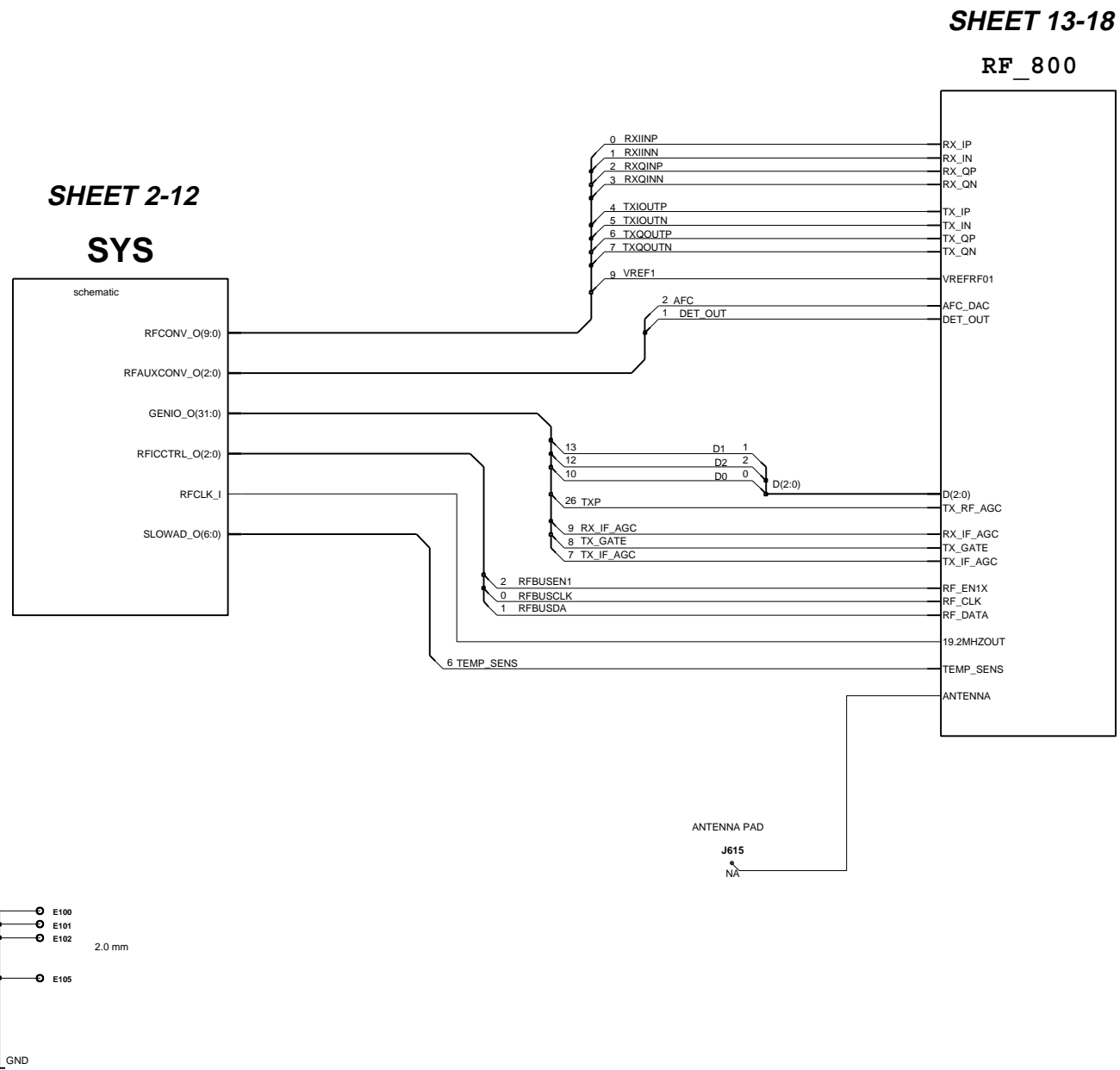

RF Top Level

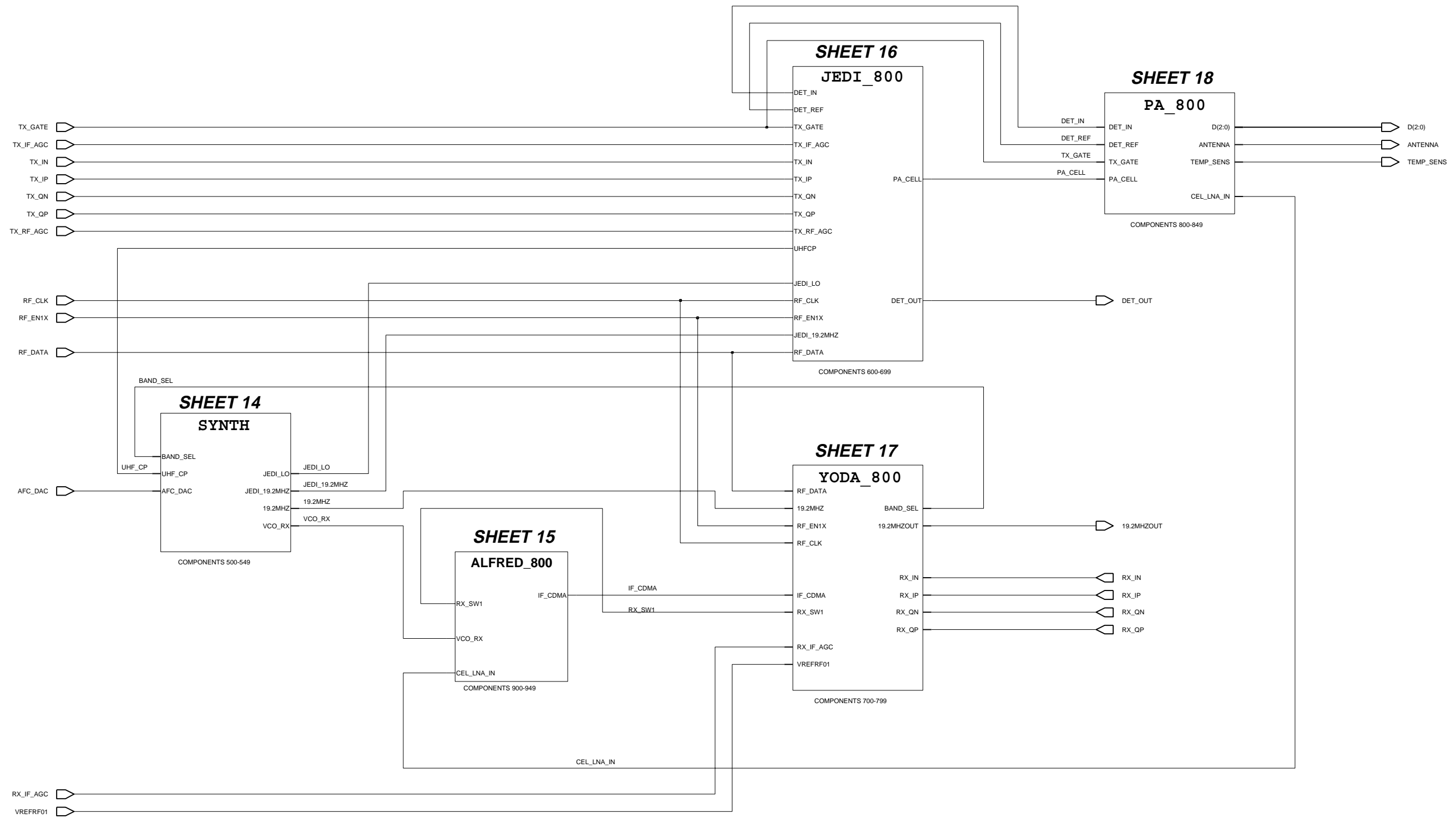

PA

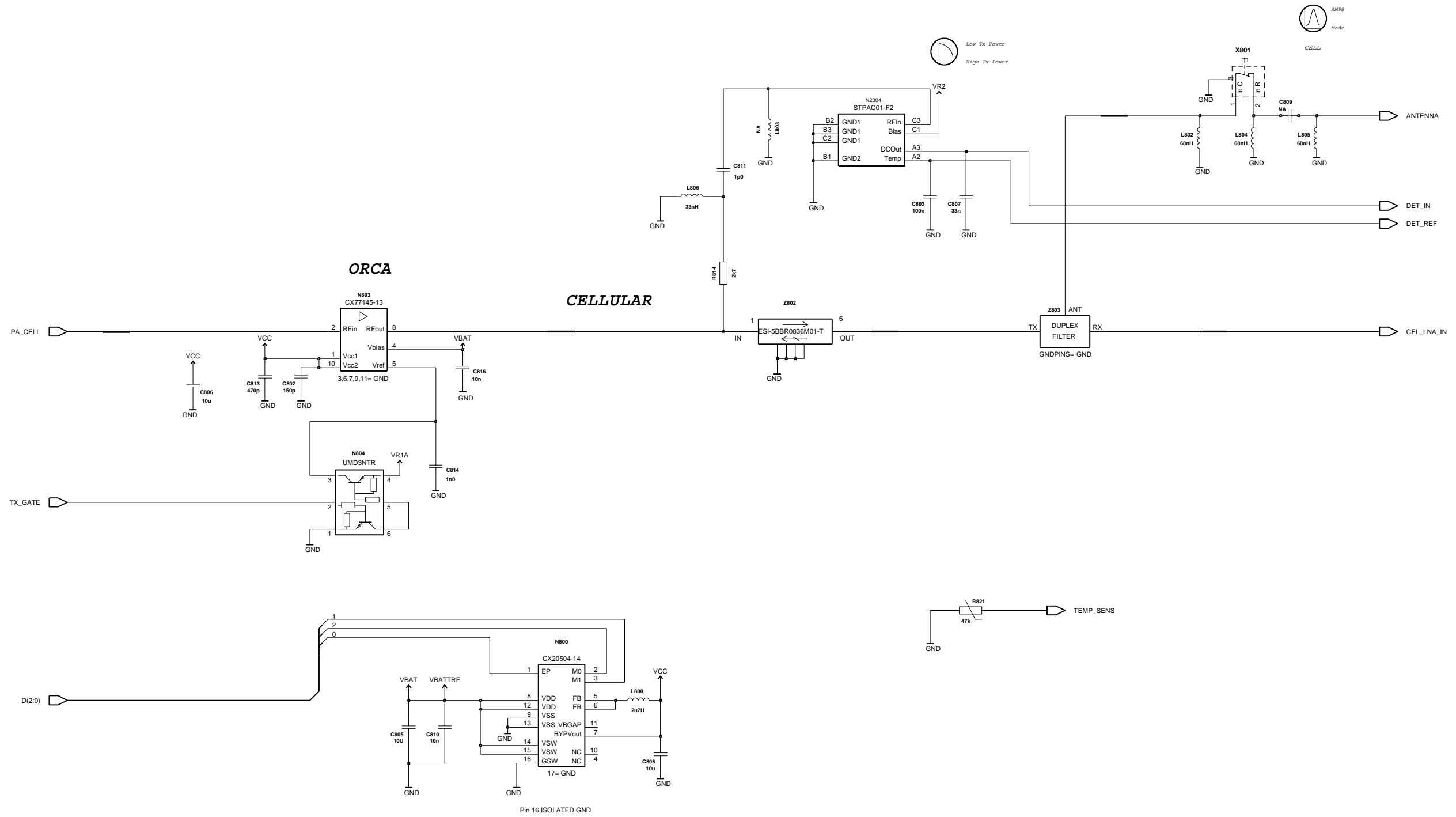

Jedi

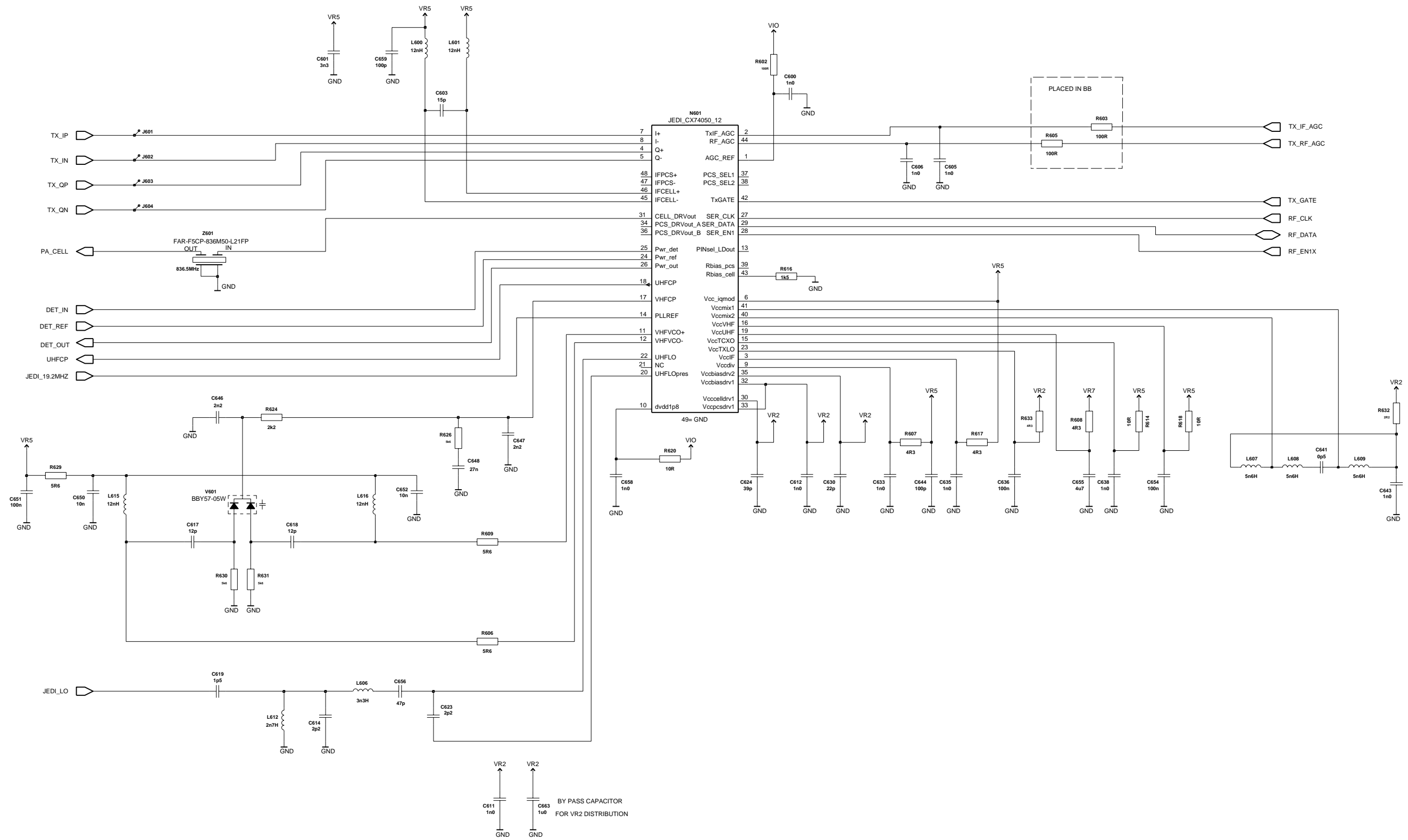

Yoda

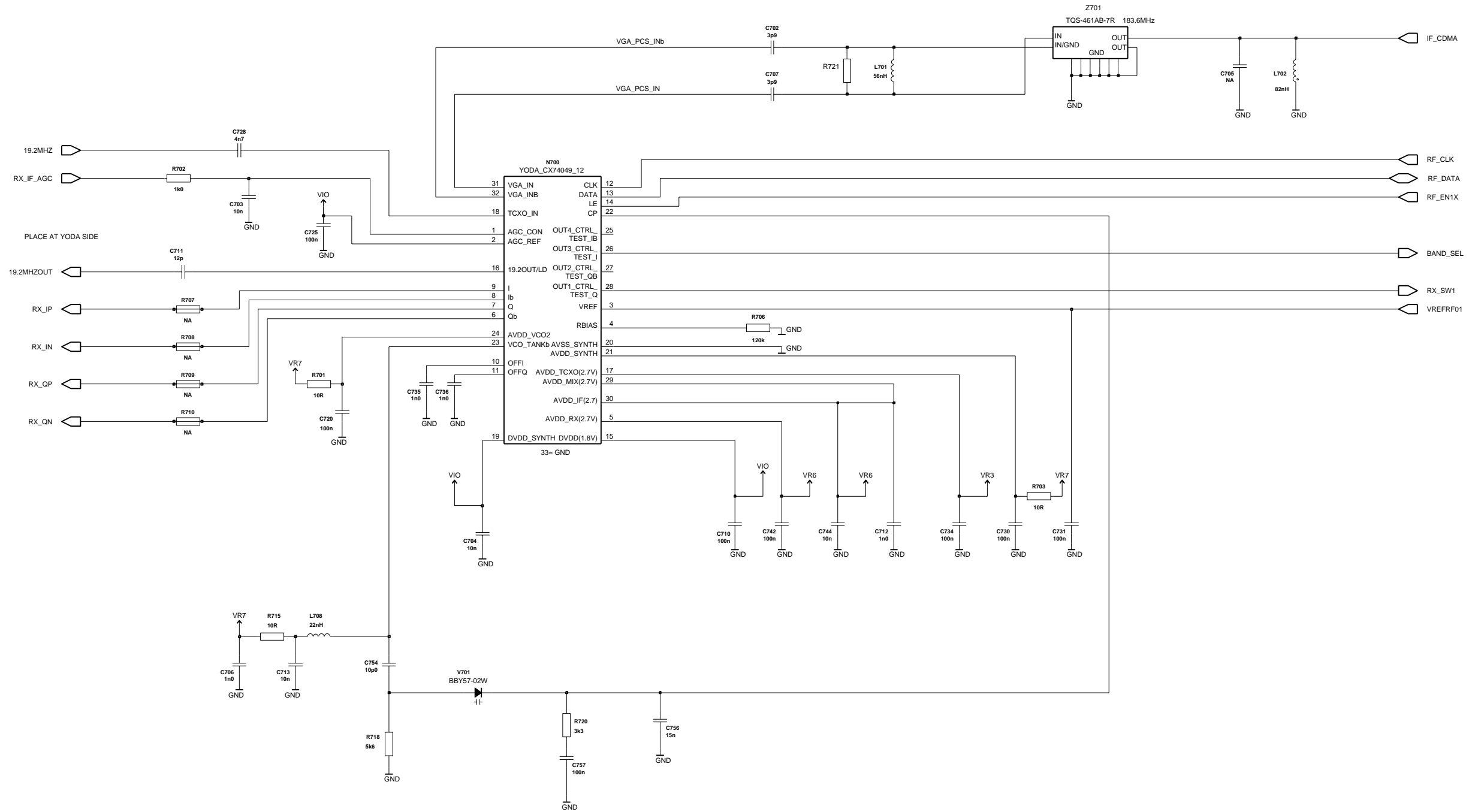

Synthesizer

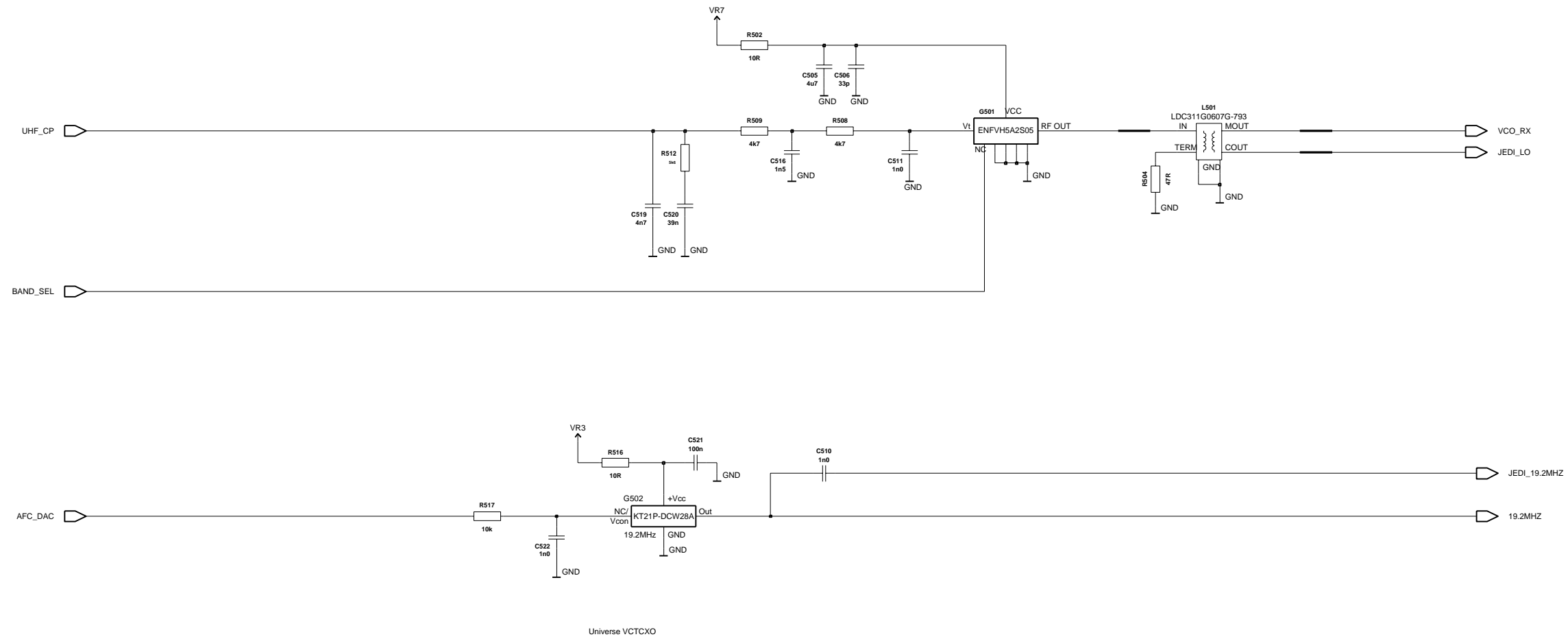

Alfred

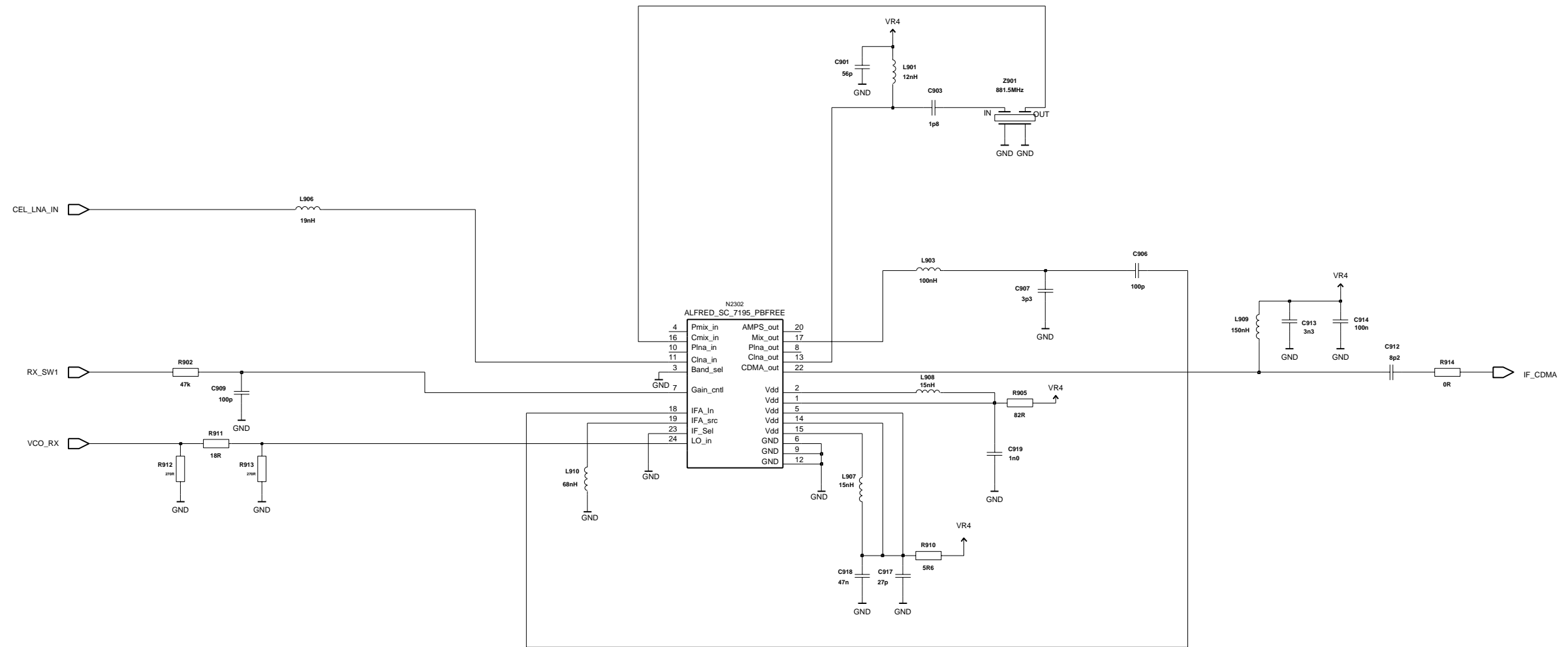

DCT4 Common Baseband

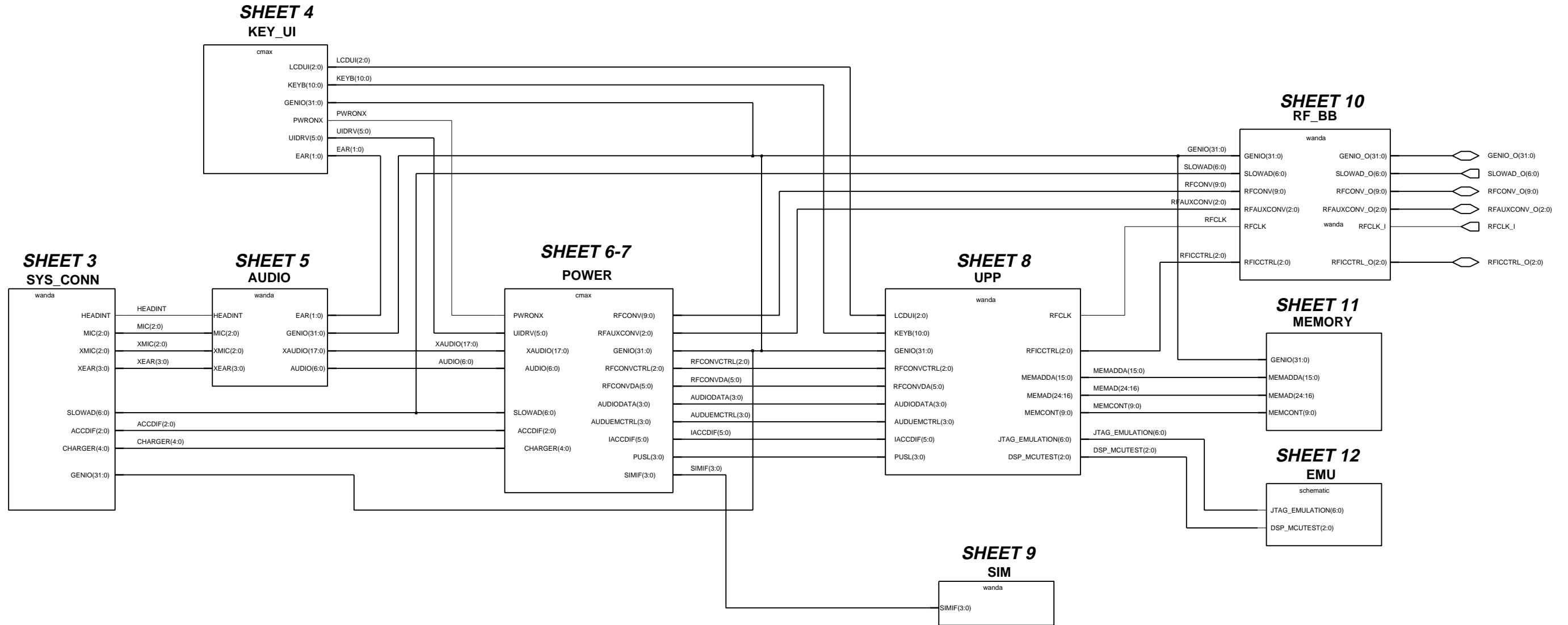



System Connector

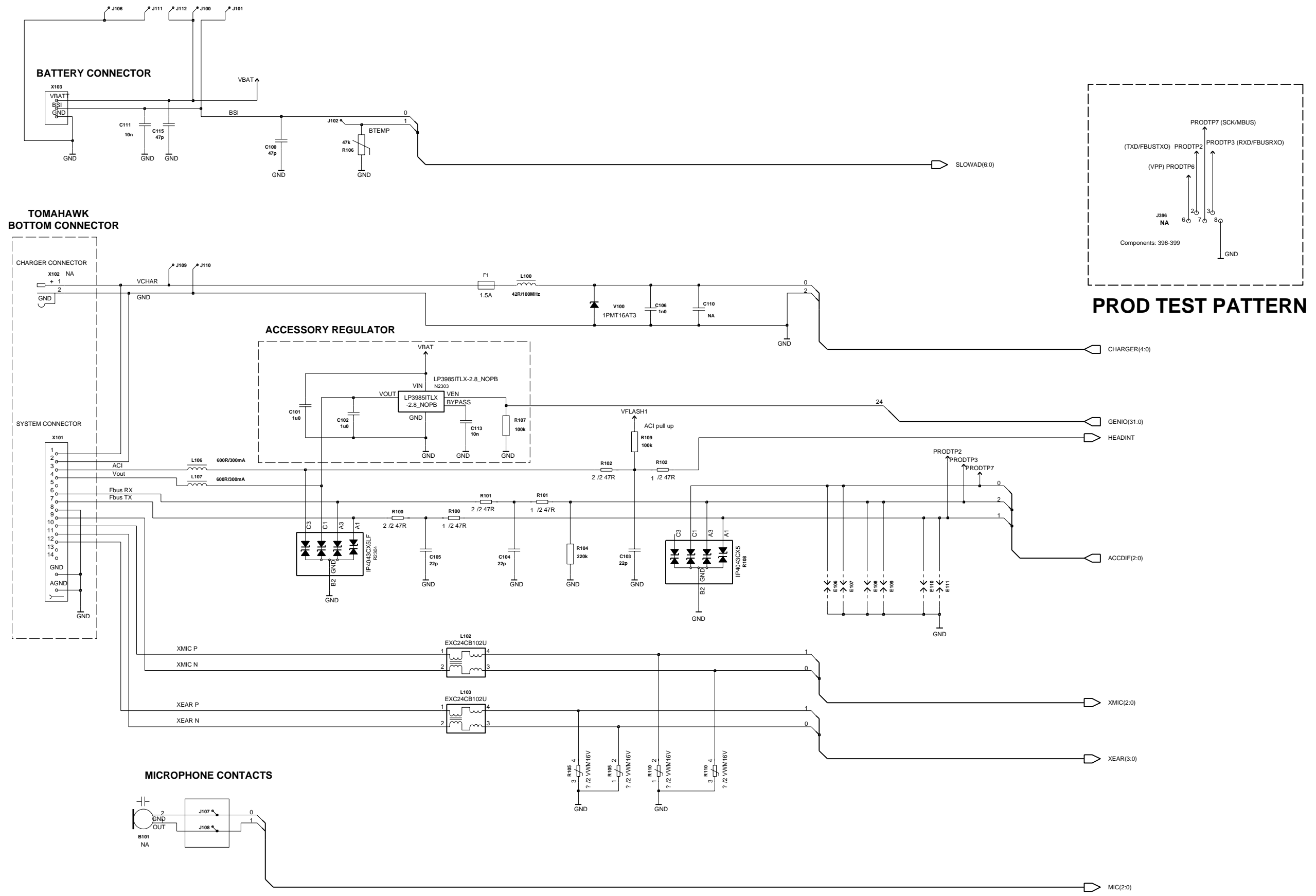

User Interface

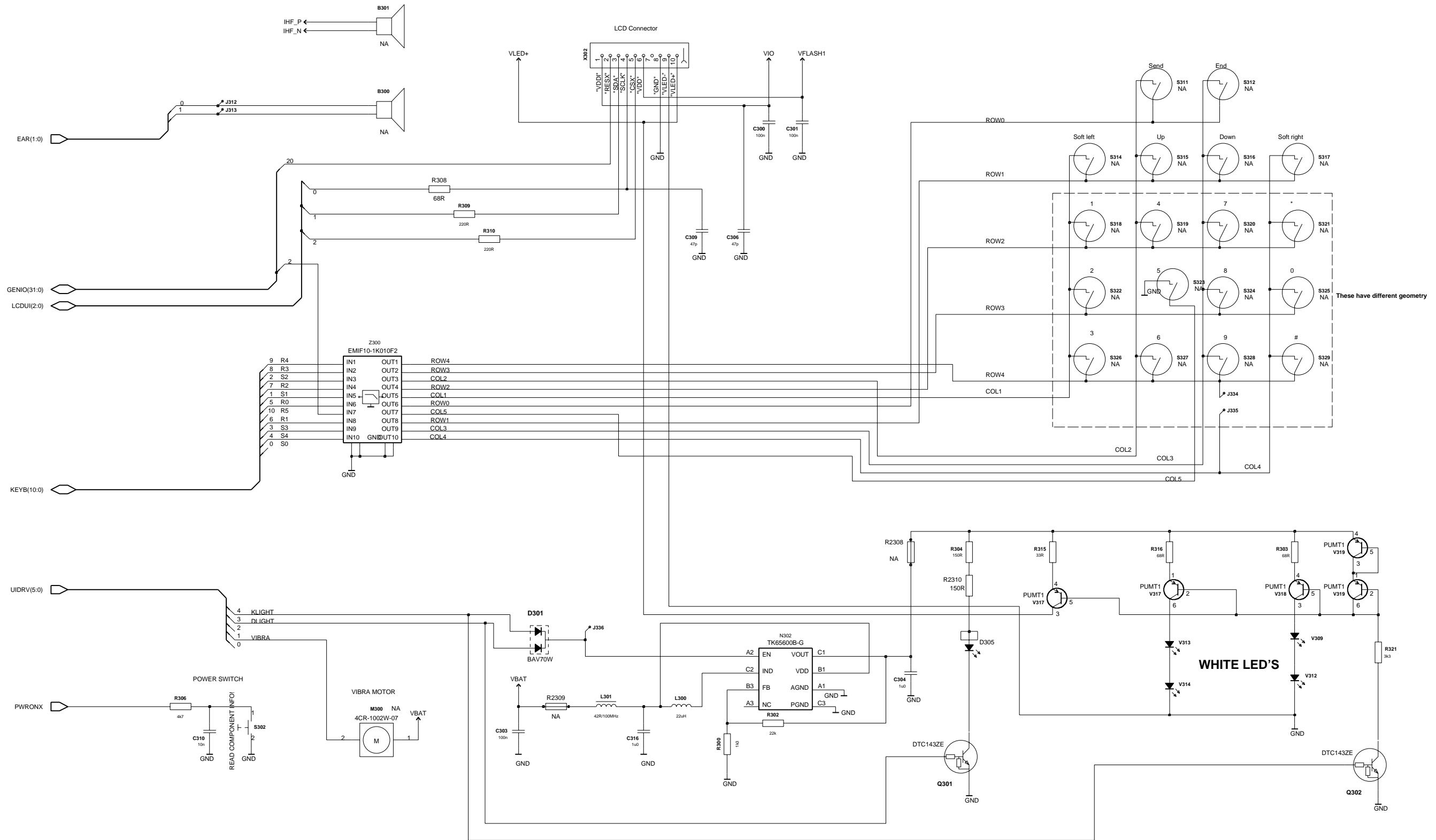

Audio

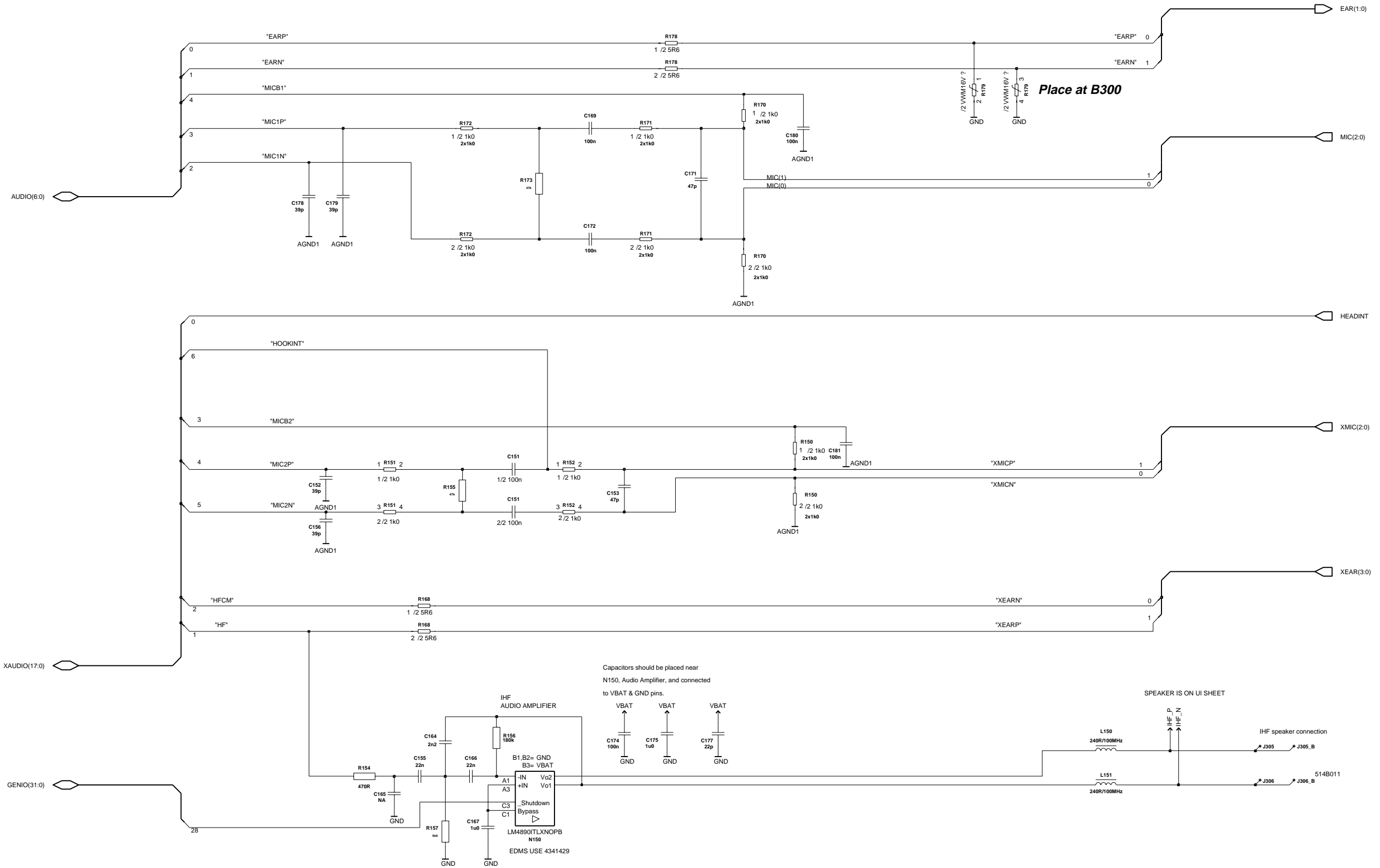

Discrete Power Management

SHEET 6

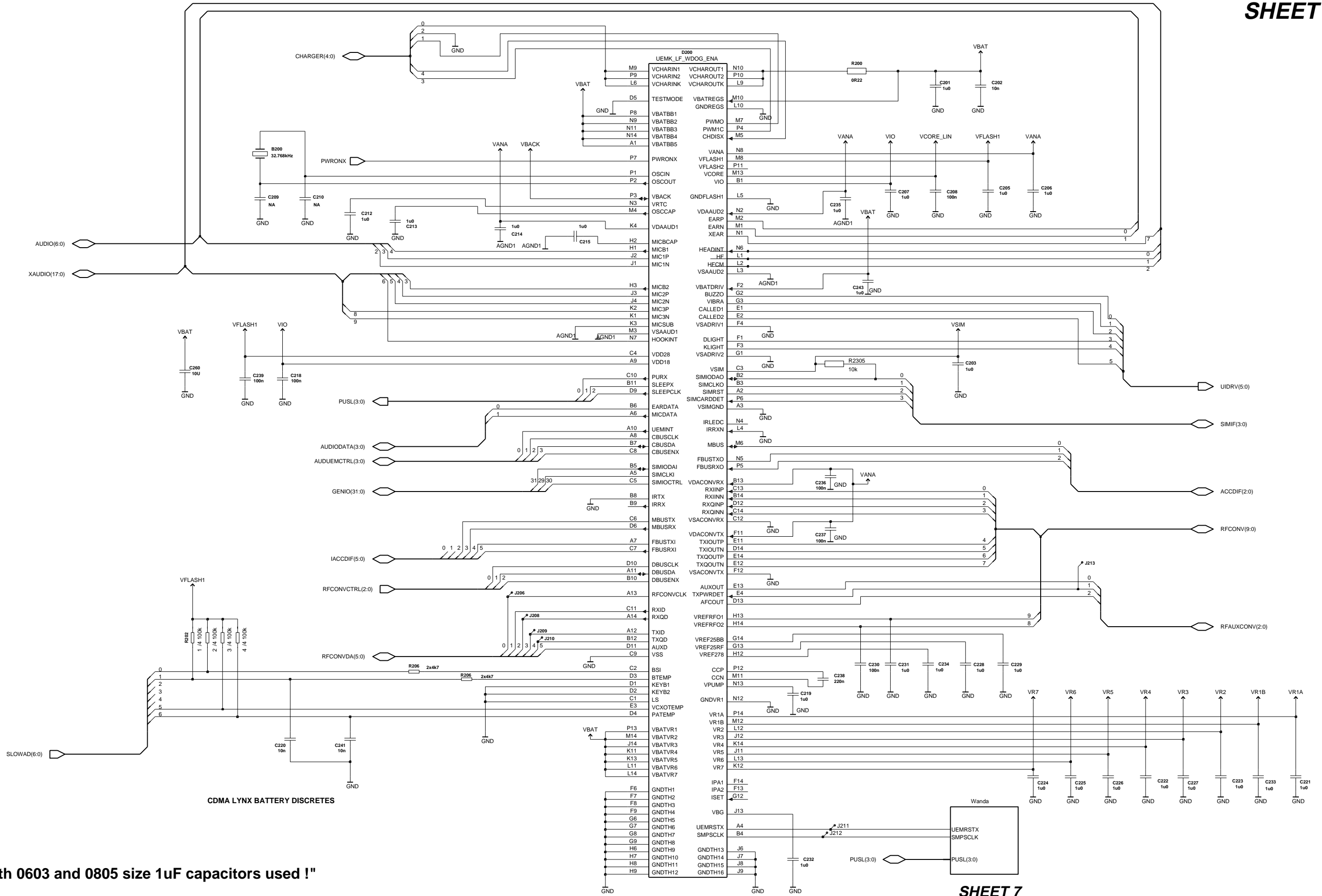

"Both 0603 and 0805 size 1uF capacitors used !"

SHEET 7

DC/DC Converter

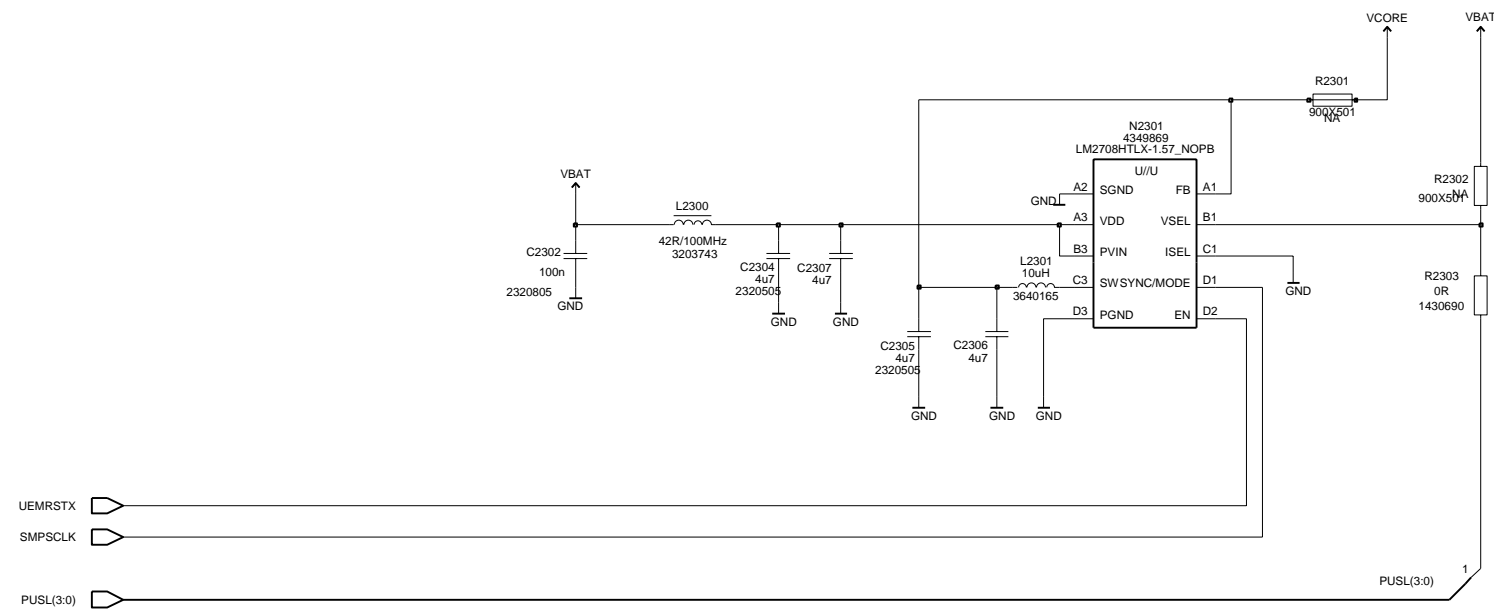

UPP

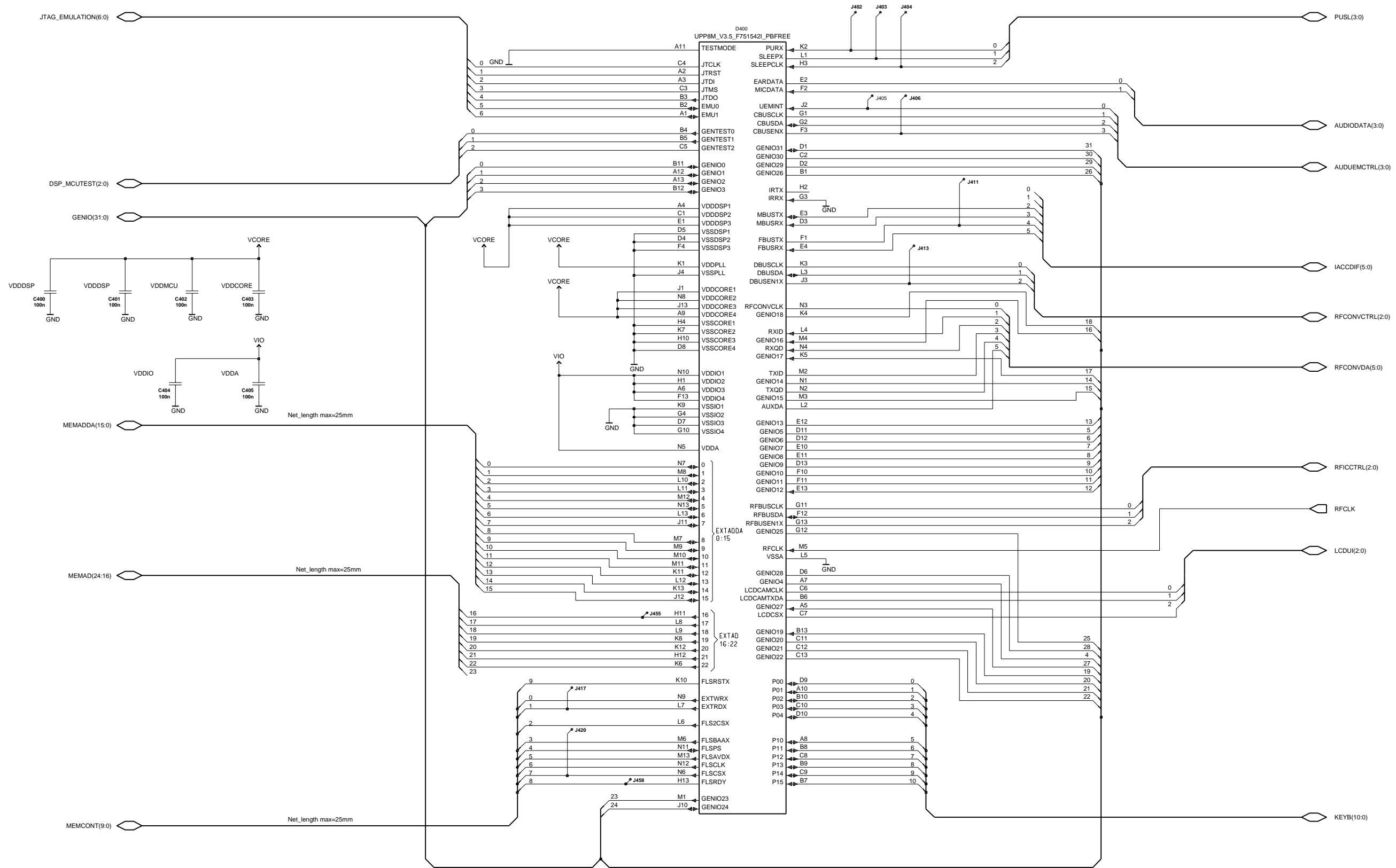

Combo Memory 128+8 Mbit

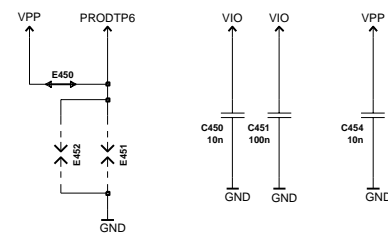
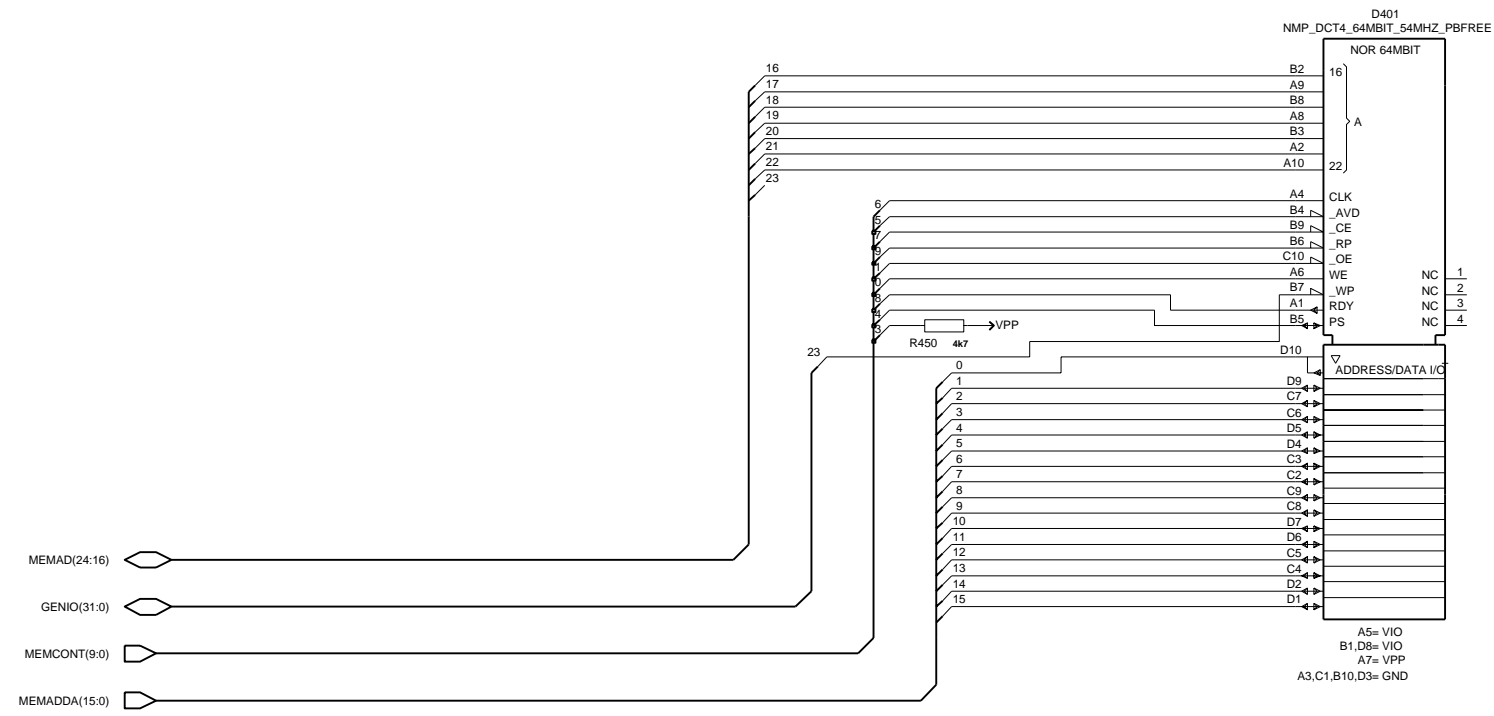

SIM Reader

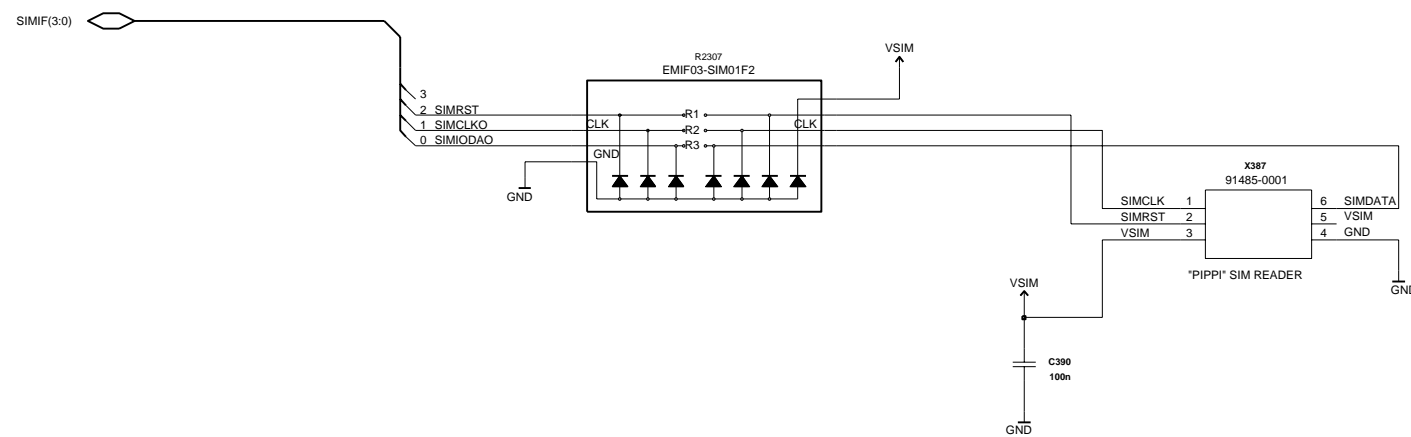

BB-RF Interface

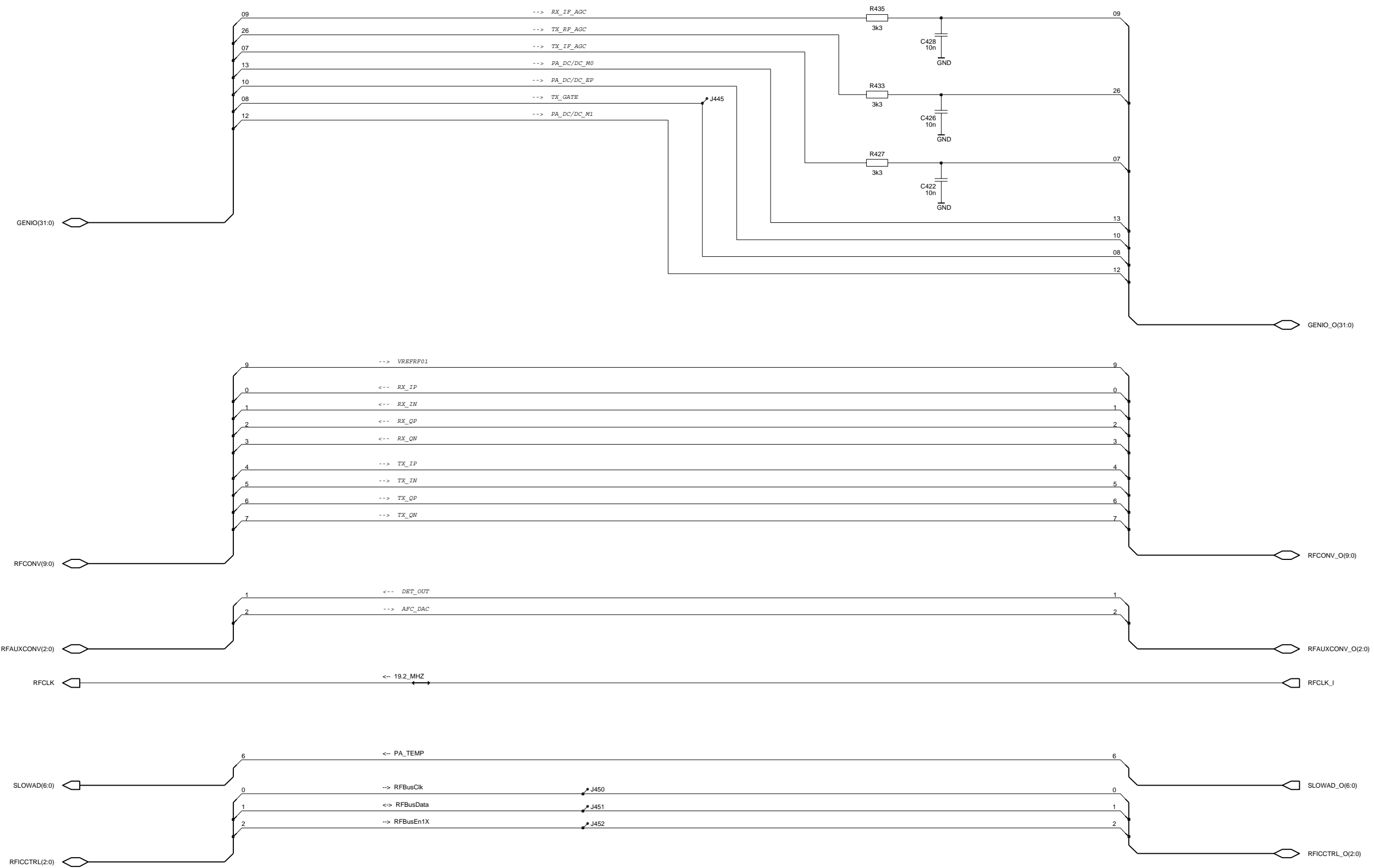



JTAG and Ostrich Connectors

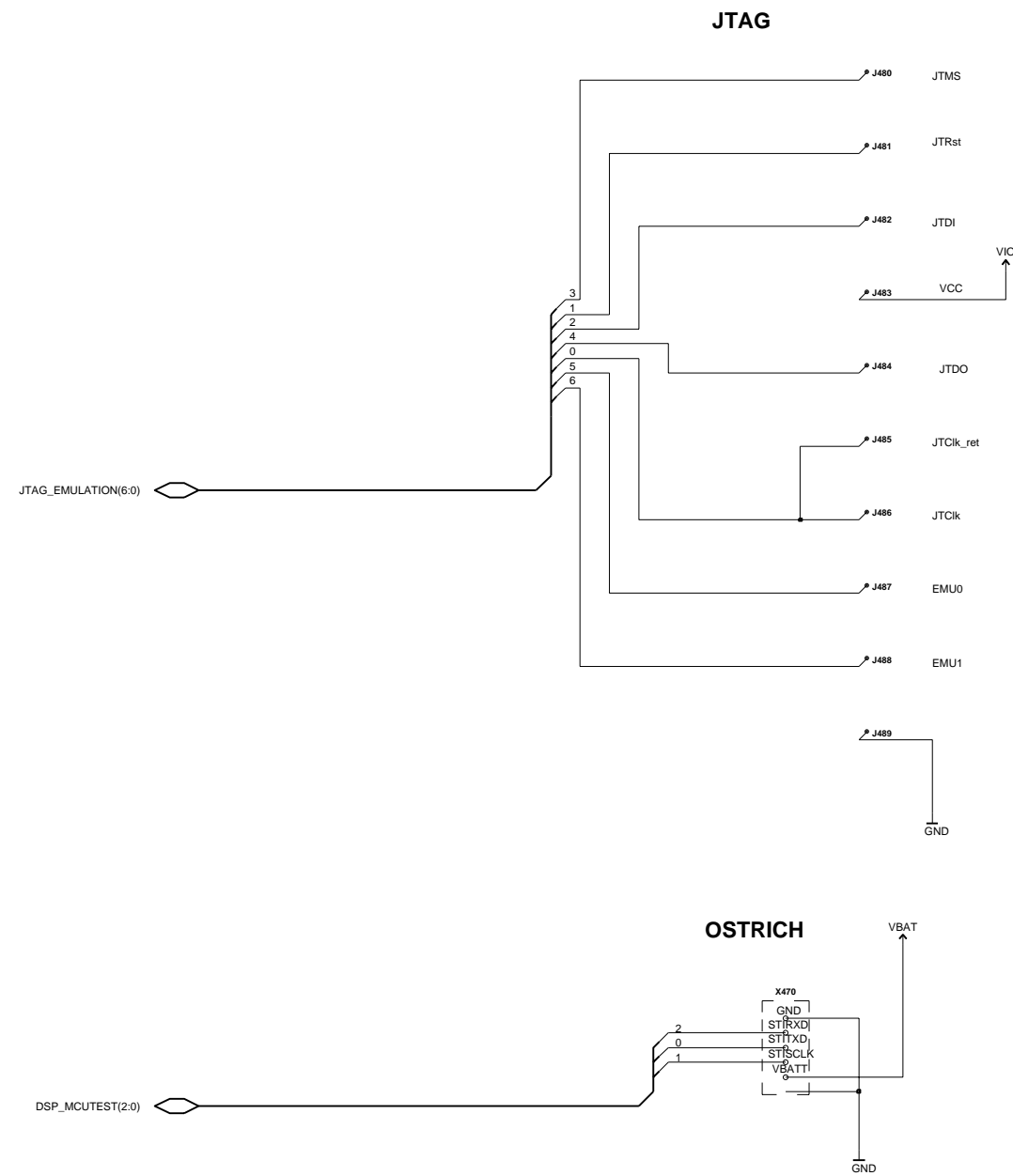

Component Layout — Top

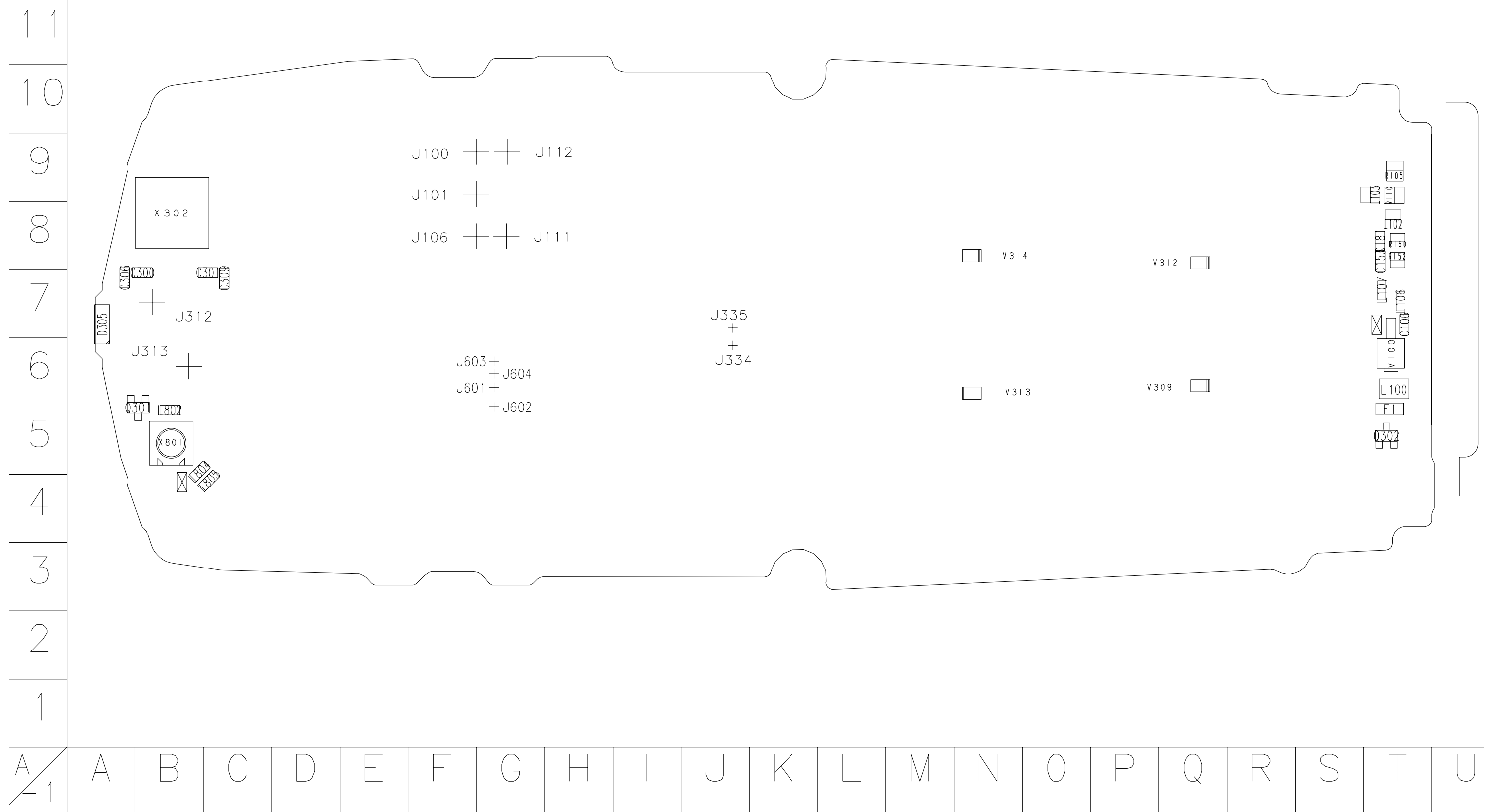

Component Layout — Bottom

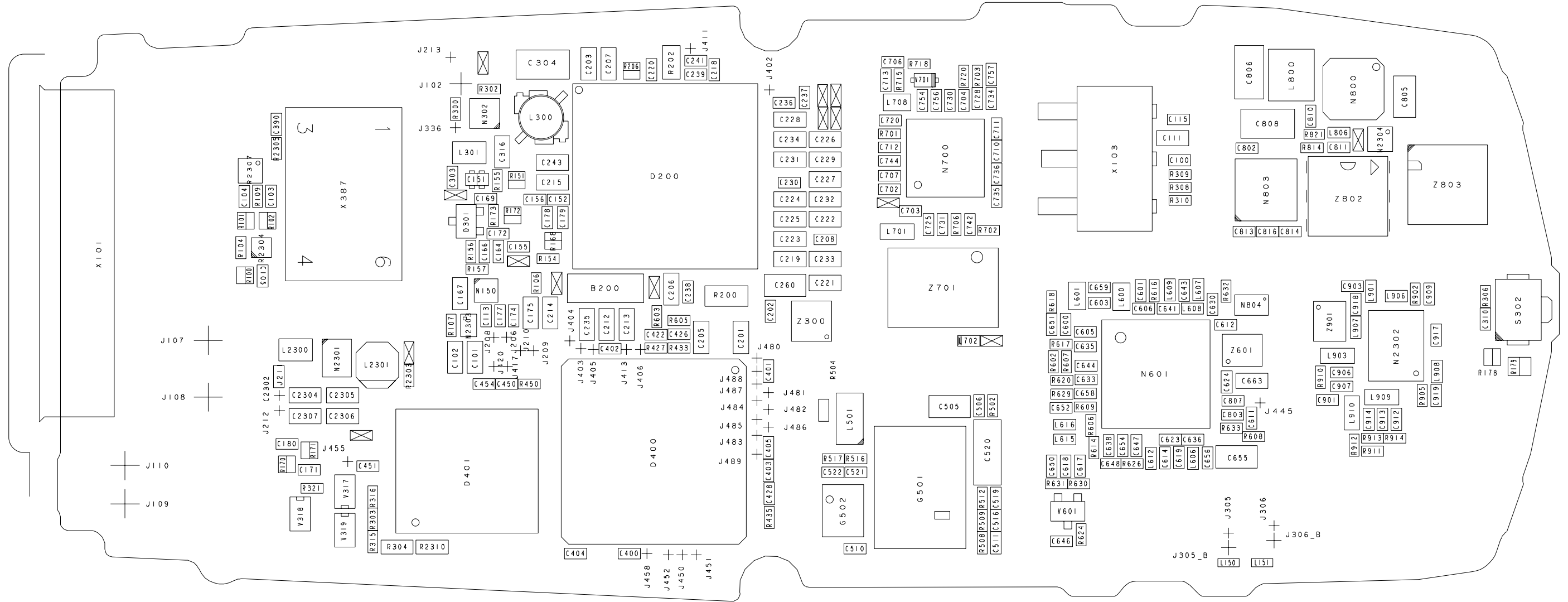

11
10
9
8
7
6
5
4
3
2
1

U	T	S	R	Q	P	O	N	M	L	K	J	I	H	G	F	E	D	C	B	A	-A
---	---	---	---	---	---	---	---	---	---	---	---	---	---	---	---	---	---	---	---	---	----

Component Values — Top

